

Model	EC-41 60Hz
Standby Power (60Hz)	33kW /41kVa
Prime Power (60Hz)	30kW /38kVa

Standard Features

General Features:

- Engine (Cummins 4BT3.9-G)
- Radiator 50°C max, fans are driven by belt, with safety guard
- 24V charge alternator
- Alternator (Stamford Type SMF & TWG II or Equal), single bearing alternator IP22/IP23, insulation class H/H
- Absorber
- Dry type air filter, double fuel filter, oil filter, coolant filter
- Main line circuit breaker
- Standard control panel
- 12V batteries, rack and cable
- Ripple flex exhaust pipe, exhaust siphon, flange, muffler
- Tools kits
- User manual

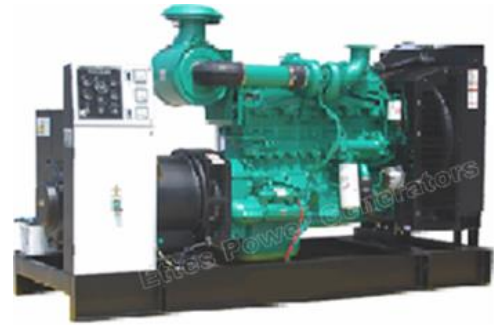

Generator Ratings

Voltage	Hz	Phase	P.F (COS ϕ)	Standby Amps	Standby Ratings (kW/kVa)	Prime Ratings (kW/kVa)
480/277	60	3	0.8	49	33/41	30/38
460/266	60	3	0.8	51	33/41	30/38
440/254	60	3	0.8	54	33/41	30/38
416/240	60	3	0.8	57	33/41	30/38

Prime Power (PRP): Prime power is available for an unlimited number of annual hours in variable load application, in accordance with GB/T2820-97 (equivISO8528); A 10% overload capability is available for a period of 1 hour within a 12-hour period of operation.

Standby Power Rating (ESP): The standby power rating is applicable for supplying emergency power for the duration of a utility power interruption. No overload, utility parallel or negotiated outage operation capability is available at this rating.

Sales Promises

Ettes Power provides a full line of brand new and high quality genset. Each unit is strictly factory tested before departure. Ettes Power Standard Warranty terms is 12 months or 1500 running hours, subject to which occurs first. Furthermore, all Cummins engines are covered by Cummins-global-United warranty and distributor service network, the user can get guarantee from Cummins service center at your local.

Engine Main Data

Manufacturer / Model:	Cummins 4BT3.9-G, 4-cycle
Air Intake System:	Turbocharged
Fuel System:	A type fuel pump
Cylinder Arrangement:	4 in line
Displacement:	3.9 L
Bore and Stroke:	102x120 (mm)
Compression Ratio:	16.5:1
Rated RPM:	1800rpm
Max. Standby Power at Rated RPM:	44kW/59HP
Governor Type:	Electronic

Alternator Specification

General Data

Compliance with GB755, BS5000, VDE0530, NEMAMG1-22, IED34-1, CSA22.2 and AS1359 standards.

Alternator Data

Manufacturer / Type:	Stamford Type TWGII & SMF or Equal
Number of Phase:	3
Connecting Type:	3 Phase and 4 Wires, "Y" type connecting
Number of Bearing:	1
Power Factor:	0.8
Protection Grade:	IP22/IP23
Altitude:	≤1000m
Exciter Type:	Brushless, self-exciting
Insulation Class, Temperature Rise:	H/H
Telephone Influence Factor (TIF):	< 50
THF:	< 2%
Voltage Regulation, Steady State:	±1%
Alternator Capacity:	37.5kVa
Alternator Efficiencies:	87.9%

Generating Set Data

Voltage Regulation:	≥±5%
Voltage Regulation, Stead State:	±1%
Sudden Voltage Warp (100% Sudden Reduce):	≤+25%
Sudden Voltage Warp (Sudden Increase):	≤-20%
Voltage Stable Time (100% Sudden Reduce):	≤6S
Voltage Stable Time (Sudden Increase)	≤6S
Frequency Reduce:	≤5% Adjustable
Frequency Regulation, Stead State:	≤1.5%

Specifications may change without prior notice

Tel: +86-22-58112239 Fax: +86-22-58112272 Cell:+86-13672013688

Website: www.ettespower.com Email: info@ettespower.com

Frequency Waving:	≤0.8%
Sudden Frequency Warp (100% Sudden Reduce):	≤+12%
Sudden Frequency Warp (Sudden Increase):	≤-10%
Frequency Recovery Time (100% Sudden Reduce):	≤5S
Frequency Recovery Time (Sudden Increase):	≤5S

Options

Engine	Fuel System	Control System
<ul style="list-style-type: none"> ● Heater 	<ul style="list-style-type: none"> ● Daily Fuel Tank ● Water Separator 	<ul style="list-style-type: none"> ● Remote Control Panel ● Auto Transfer Switch (ATS) Control Panel ● Paralleling System ● Electricity Output Cabinet

Alternator	Others	Data
<ul style="list-style-type: none"> ● Anti Condensation Heater ● (PMG) Permanent Magnet Generator ● Drop CT (For Paralleling) 	<ul style="list-style-type: none"> ● Rainproof Type ● Soundproof Type ● Trailer Type 	<ul style="list-style-type: none"> ● Engine Parts Drawing List ● Spare Parts

Dimension & Weight

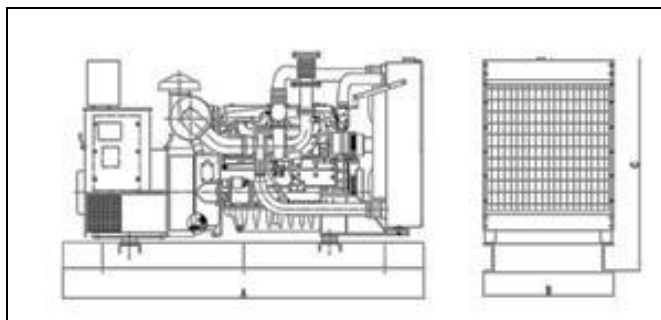

Standard (Open Type) Without Base Fuel Tank

Overall Size: 1820 (mm) x760 (mm) x1400 (mm)
Weight: 890kg

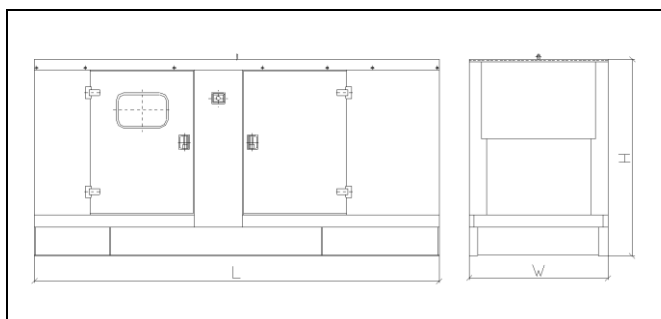

Soundproof Type

Overall Size: 2230 (mm) x1060 (mm) x1680 (mm)
Weight: 1350 kg

Standard Control Panel/LCD



Ettes Power Standard Control Panel, usually adopts control module of UK Deepsea DSE6020 or Smartgen 6120 or 7110 series or Equal, using micro processing techniques integrating digital, intelligent and network techniques which can carry out functions including auto start/stop, data measure, alarming. The controller uses LCD display, optional Chinese and English display interface with operation easy and reliable. It can be widely used in all types of generator automatic control system for compact structures, advanced circuits, simple connections and high reliability.

Auto Module Control Panel/Automatic Transfer Switch



Auto Module Control Panel, usually adopt control module of UK Deepsea DSE 7320 or Smartgen 7120 or Equal, is the configuration for nobody on duty generators control, This kind of panel adopts auto module control system, with large LCD display to show the menu.

Features: receive remote output signal from ATS and realize auto start and stop of generators.

RS232 or 485 interface which can communicate with PC to realize remote operation.

Auto Mains Failure controller, can realize furthermore can detect ATS and control directly.

Auto Synchronization Parallel Control Panel



Automatic Parallel Control Panel, usually adopting intelligent control module of UK Deepsea DSE8610/8620 or Smartgen 9500 Series Equal, This new automatic parallel system is inserted and folded installed, no need the peripheral relay and logic circuit. The main switch adopts electronic breaker or frame breaker, combined together with the generator, which is very reliable. One generator, one panel. The panel can be used both for single genset working or Gensets Parallel working. This kind of panel also can be used to parallel generator when the capability of the power plant needs to be enlarged in the future.